



充电式打孔机 PP001G



XGT 40V Li-ion max

自动打孔返回

冲孔循环完成后，液压机构自动将冲头从工件上拔出并返回到初始位置，以实现高效的连续冲孔。

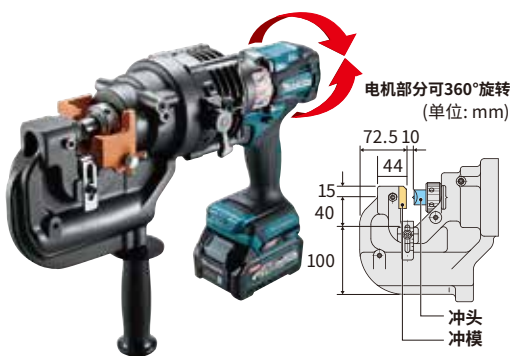
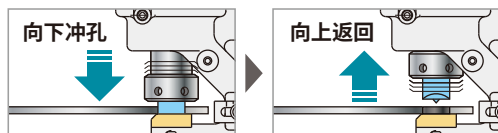

小型化设计



回位杆



便携式液压工具 (无需液压软管)

高效冲孔

工作时间

减少约

46%

与我们的18V型号相比

最大冲孔能力

切割材料: 普通钢 (SS400)

∅20
t9mm

∅19
t10mm

与各种钢材兼容

冲孔能力

扁钢 最大: 80mm x t9 (中心冲孔)

槽钢 最小: 75mm x 40mm 最大: 125mm x 65mm (法兰冲孔)

角钢 最小: 40mm x 40mm x t3 最大: 80mm x 80mm x t9

H型钢 最小: 100mm x 100mm 最大: 300mm x 150mm

扁钢



角钢



槽钢



H型钢



附件

冲头与模具的组合

·在薄结构金属板上打孔可能会导致板变形和孔上的毛刺。
·如果您需要精密冲压，请参阅下表以选择冲头和模具的最佳组合。

● 圆形冲孔										
冲头		冲模		切割材料		冲模		切割材料		
孔径 (mm)	部件号	孔径	部件号	软钢	铝	孔径	部件号	软钢	不锈钢 (Inox)	槽钢
6	SC05340040	SA6	SC00000202	t2-t3.2	t2-t3.2	SB6	SC00000203	t2-t4	t3-t4	-
6.5	SC05340050	SA6.5	SC00000204	t2-t3.2	t2-t3.2	SB6.5	SC00000205	t2-t6	t3-t4	-
8	SC05340060	SA8	SC00000206	t2-t3.2	t2-t3.2	SB8	SC00000207	t2-t6	t3-t4	-
8.5	SC05340070	SA8.5	SC00000208	t2-t3.2	t2-t3.2	SB8.5	SC00000209	t2-t6	t3-t4	-
10	SC05340080	SA10	SC00000210	t2-t3.2	t2-t3.2	SB10	SC00000211	t2-t6	t3-t4	t8
11	SC05340090	SA11	SC00000212	t2-t3.2	t2-t3.2	SB11	SC00000213	t3-t9	t3-t6	t8
12	SC05340100	SA12	SC00000214	t2-t3.2	t2-t3.2	SB12	SC00000215	t3-t9	t3-t6	t8
13	SC05340110	SA13	SC00000216	t2-t3.2	t2-t3.2	SB13	SC00000217	t3-t9	t3-t6	t8
14	SC05340120*	SA14	SC00000218	t2-t3.2	t2-t3.2	SB14	SC00000219*	t3-t9	t3-t6	t8
15	SC05340130	SA15	SC00000220	t2-t3.2	t2-t3.2	SB15	SC00000221	t3-t9	t3-t6	t8
16	SC05340140	-	-	t2-t3.2	t2-t3.2	SB16	SC05332710	t3-t9	t3-t6	t8
18	SC05340150	SA18	SC00000222	t2-t3.2	t2-t3.2	SB18	SC00000223	t3-t9	t3-t6	t8
19	SC05340170	-	-	-	-	SB19	SC05332740	t3-t9	t3-t6	t8
20	SC05340160	SA20	SC05352500	t2-t3.2	t2-t3.2	SB20	SC05352510	t3-t9	t3-t6	t8

*为标准附件

● 长椭圆冲孔										
冲头		冲模		切割材料		冲模		切割材料		
孔径 (mm)	部件号	孔径	部件号	软钢	铝	孔径	部件号	软钢	不锈钢 (Inox)	槽钢
6.5x10	SC05340200	A6.5x10	SC00000243	t2-t3.2	t2-t3.2	B6.5x10	SC00000244	t2-t6	t3-t4	-
6.5x13	SC05340210	A6.5x13	SC00000245	t2-t3.2	t2-t3.2	B6.5x13	SC00000246	t2-t6	t3-t4	-
8.5x13	SC05340220	A8.5x13	SC00000247	t2-t3.2	t2-t3.2	B8.5x13	SC00000248	t2-t6	t3-t4	-
8.5x17	SC05340230	A8.5x17	SC00000249	t2-t3.2	t2-t3.2	B8.5x17	SC00000250	t2-t6	t3-t4	-
9x13.5	SC05340240	A9x13.5	SC00000251	t2-t3.2	t2-t3.2	B9x13.5	SC00000252	t2-t6	t3-t4	-
9x18	SC05340250	A9x18	SC00000253	t2-t3.2	t2-t3.2	B9x18	SC00000254	t2-t6	t3-t4	-
10x15	SC05340260	A10x15	SC00000255	t2-t3.2	t2-t3.2	B10x15	SC00000256	t2-t8	t3-t6	t8
10x20	SC05340270	A10x20	SC00000257	t2-t3.2	t2-t3.2	B10x20	SC00000258	t2-t8	t3-t6	t8
11x16.5	SC05340280	A11x16.5	SC00000259	t2-t3.2	t2-t3.2	B11x16.5	SC00000260	t2-t9	t3-t6	t8
12x18	SC05340290	A12x18	SC00000261	t2-t3.2	t2-t3.2	B12x18	SC00000262	t2-t9	t3-t6	t8
13x19.5	SC05340300	A13x19.5	SC00000263	t2-t3.2	t2-t3.2	B13x19.5	SC00000264	t2-t9	t3-t6	t8
14x21	SC05340310	A14x21	SC00000265	t2-t3.2	t2-t3.2	B14x21	SC00000266	t2-t9	t3-t6	t8
15x21	SC05340320	-	-	-	-	B15x21	SC05340550	t2-t9	t3-t6	t8

滑动挡块

部件号: SC03300790

使用可选的滑动止动器，可以从工件边缘冲压出高达40mm的深度。



充电时间

40V Li-ion max	快速 充电	
	DC40RA	DC40RC
*1 BL4020 2.0Ah	22 min	30 min
*1 BL4025 2.5Ah	28 min	38 min
*1 BL4040/F4.0Ah	45 min	67 min
*1 BL4050F5.0Ah	50 min	85 min
*1 BL4080F8.0Ah	76 min	170 min

*推荐的电池

● 圆形冲孔



● 圆形冲孔											
冲头		冲模		切割材料		冲模		切割材料			
孔径 (mm)	部件号	孔径	部件号	软钢	不锈钢 (Inox)	槽钢	孔径	部件号	软钢	不锈钢 (Inox)	槽钢
-	-	-	-	-	-	-	-	-	-	-	-
-	-	-	-	-	-	-	-	-	-	-	-
-	-	-	-	-	-	-	-	-	-	-	-
-	-	-	-	-	-	-	-	-	-	-	-
-	-	-	-	-	-	-	-	-	-	-	-
-	-	-	-	-	-	-	-	-	-	-	-
-	-	-	-	-	-	-	-	-	-	-	-
12	SC05340400	SB12	SC00000215	t10	t3-t6	t10	-	-	-	-	-
13	SC05340410	SB13	SC00000217	t10	t3-t6	t10	-	-	-	-	-
14	SC05340420	SB14	SC00000219	t10	t3-t6	t10	-	-	-	-	-
15	SC05340430	SB15	SC00000221	t10	t3-t6	t10	-	-	-	-	-
16	SC05340440	SB16	SC05332710	t10	t3-t6	t10	-	-	-	-	-
18	SC05340450	SB18	SC00000223	t10	t3-t6	t10	-	-	-	-	-
19	SC05340460	SB19	SC05332740	t10	t3-t6	t10	-	-	-	-	-
20	-	-	-	-	-	-	-	-	-	-	-

● 纵向长椭圆冲孔

冲头		冲模		切割材料		
孔径 (mm)	部件号	孔径	部件号	软钢	不锈钢 (Inox)	槽钢
20x12	SC05340350	B20x12	SC05340510	t2-t9	t3-t6	t8/t7.5
20x14	SC05340360	B20x14	SC05340530	t2-t9	t3-t6	t8/t7.5

工作台(选购件)

部件号: SC03801080



充电式打孔机

PP001GZK

能力	钢: 20 mm 不锈钢: 20 mm
声压等级	77 dB(A)
振动等级	2.5 m/s ² or less
尺寸(长 x 宽 x 高)	使用BL4020 / BL4025: 398 x 129 x 315 mm (15-5/8 x 5-1/8 x 12-3/8")
净重	11.6 - 12.8 kg (25.6 - 28.2 lbs.)
净重(电池)	BL4020 - BL4080F

携带箱

标准附件:

冲头, 冲模, 把手, 紧固螺母杆, 六角扳手, 扳手, 携带箱

规格和设计如有变更, 恕不另行通知



牧田(中国)有限公司



微信公众号



抖音号

全国查询电话

www.makita.com.cn

400-928-6517

(接听时间: 8:00-17:00, 节假日除外)